



INSTALLATION AND USER GUIDE

ADVANCE SFUTS MULTI-FUEL THERMAL STORE



ADVANCE APPLIANCES LTD

**PLEASE RETAIN AND ENSURE SERVICE RECORDS
ARE KEPT UP TO DATE.**

SCHEMATIC DIAGRAM OF UNIVERSAL THERMAL STORE

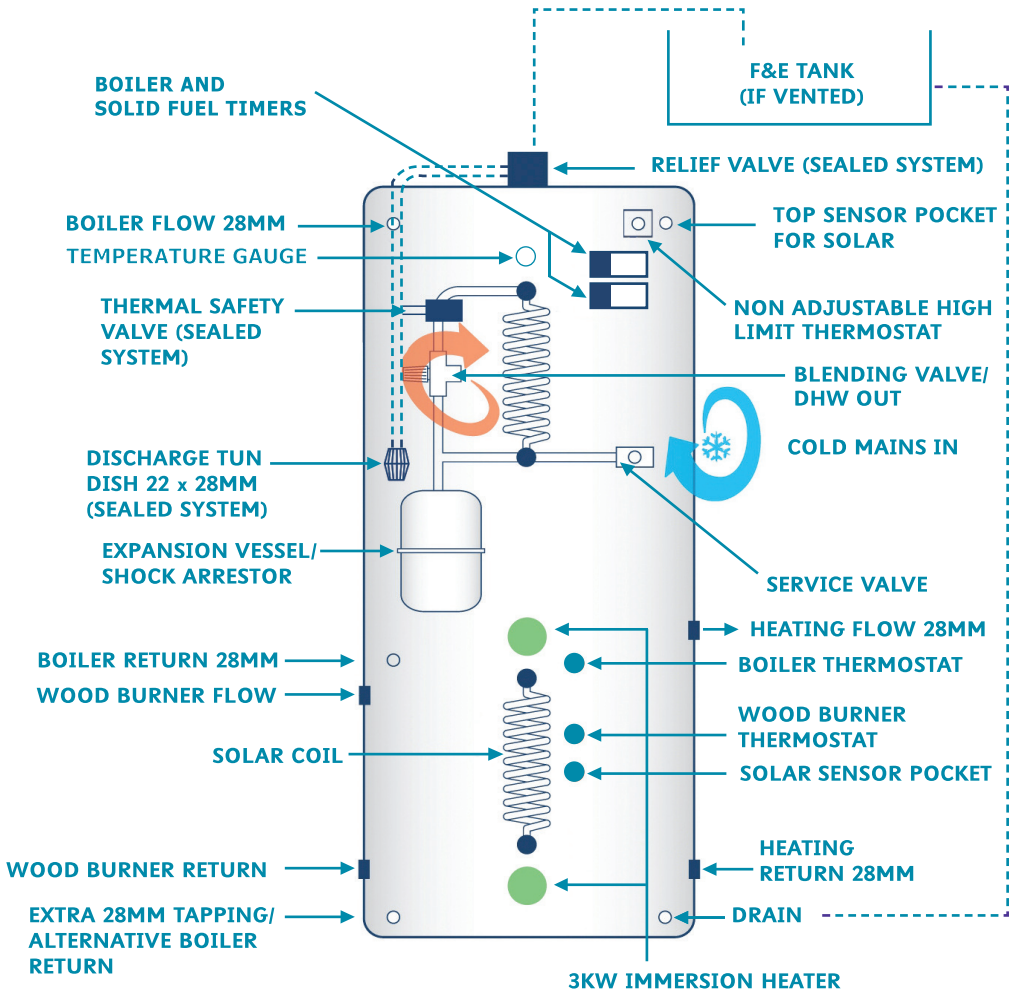

IMPORTANT: Gravity circulation must be achievable through the store from the woodburner. The store must be on the same level or higher - see diagram on page 6.

Note: The immersion heater supplied is fitted with a thermal cut out. This is an essential safety equipment, and immersion heaters without thermal cut outs must not be used.

Note: Woodburners up to a maximum of 30KW output can be safely fitted.

Note: All local regulations including those in reference to national standards must be complied with when installing the product, including provisions surrounding electrical safety.

INTRODUCTION

The Advance Universal Thermal Store linking system is a major step forward in the design and operation of thermal store systems, allowing for a number of heat inputs to work together for a fully flexible vented or sealed central heating and mains pressure hot water system.

OPERATION

Traditional boilers can be used to heat the thermal store (or heat bank as it is sometimes called). Any boilers used in conjunction with this product should be provided with a boiler thermostat and energy cut out set such that under no circumstances can the primary flow temperature exceed 100°C. The boiler must be capable of delivering a temperature of 75°C.

If there is any possibility of gravity circulation or pump over-run from the boiler then consideration should be given to fitting a zone valve and by-pass on the boiler flow circuit wired to close once the store temperature thermostat is satisfied. This also prevents boiler over-run reducing the temperature of the store. (Please see Page 12 for installation recommendation). Boilers can be left live 24hrs as heat loss is minimal. A timer is fitted and pre-wired. The timer can be set to turn the boiler on and off, for example to prevent any nuisance overnight firing.

Other appliances can be connected to the flow and return tapplings on the store. These tapplings can be used for low input devices such as solid fuel stoves, biomass, cookers and so on. A special pipe set is provided for this purpose. The bottom coil is for a solar thermal input, but can also be used for other suitable inputs. Two 3kw immersion heaters are fitted, a low position 3kw immersion heater which can assist on extremely low temperature days and a mid position one for hot water boost if needed. These can be coupled to solar PV or the mains supply.

Central heating is drawn from side tapplings.

Insulation on this store is excellent, 60mm thick, foam injected with a smart outer case.

The store is capable of working up to 3 bar pressure, making it suitable for all heating circuits, including underfloor, either sealed or open systems.

Hot water is supplied through an efficient internal heat exchanger at mains pressure for fast, safe hot water delivery and is controlled by a pre-plumbed fitted manifold with blending valve and shock arrestor fitted for easy installation.

Note: Units operate at 75°C and heat pumps cannot be the prime heating source.

Solar and Ancillary inputs

We can only offer general advice regarding external appliances and fittings. The first rule is to follow manufacturer's instructions. Use the solar sensor pockets to control the inputs on the store, and use the spare top pocket as overheat protection for solar thermal installations.

In summer - the solar season can run from April to September - wood burners, boilers and other inputs other than solar should not be necessary, as solar input should exceed the likely hot water requirements during this season. You can set the solar control to 80°C in the tank, giving ample hot water for domestic needs. An extra pocket is fitted into the store for solar over heat protection.

In installations where the thermal store is sited above the solar collector panels and if gravity circulation is possible through the solar pump an additional zone valve may be required.

Unless connected to photovoltaic solar systems the immersion heaters should not be required during the solar season, although the top one can be wired to a switched spur for any essential top up.

The immersion heaters should be set at 75°C.

Note: The immersion heater supplied is fitted with a thermal cut out. This is an essential safety requirement, and immersion heaters without thermal cut outs must not be used.

As it is a thermal store, thermal disinfection is not needed.

Some degree of experimentation in operation is likely as different systems will have different loads placed upon them.

Solid fuel systems are ideal – biomass, wood burning stoves or cookers can all be connected. It is possible to meet sealed system G3 requirements of Building Regulations by using the fully assembled SFUTS where the wiring and plumbing is provided.

ALWAYS CONNECT THE WOOD BURNER TO THE STORE WITH COPPER PIPE NOT PLASTIC.

Ancillary input is generally of an intermittent nature – for example a wood burner is usually only lit during certain periods of the day and should not be used at all in warmer weather where solar may be more appropriate. It is recommended that a gas/oil boiler is used with any intermittent heat source. Whilst it is possible to use electricity it can be expensive and off peak tariffs are preferred. Solar PV can be used.

Heat pumps are an option but it must be understood that the store operates at 75°C. It is essential that a heat source such as a gas or oil boiler is used for top up and that they achieve at least 75°C output. Each input has a dedicated thermostat so 75°C is easy to achieve with a wood burner for example and will result in substantial savings on gas or oil bills.

VENTED OR SEALED SYSTEMS

The SFUTS can be installed as either vented or sealed. It can be one or the other.

Note: For venting the woodburner circuit only, please see installers tips page 14.

A vented version will not have the thermal safety valve, pressure relief valve or tun-dish. It must be vented at the top of the tank and fed at a neutral point in the system.

The standard unit is for use with sealed heating systems. We recommend fitting this unit as it eliminates the need for a remote feed and expansion tank, suits underfloor systems and is easier to fit. There are appropriate levels of control and safety approved to meet part G of the building regulations fitted to the store, even with solid fuel inputs.

For over-temperature control a high limit thermostat turns on the heating pump which acts as a large heat dump. If the temperature in the store still continues to rise a non electrical thermal safety valves opens to allow cold water through the hot water coil to cool the store.

For over pressure, a relief valve is fitted to the top of the tank. The pressure relief and thermal safety valves are pre plumbed into a 28mm tun-dish for safe discharge.

We suggest an extra 3 bar relief valve is fitted in open circuit for additional safety into the filling loop with appropriate isolation.

The unit should be filled via a filling loop (not supplied) to 1 bar pressure cold. It has a maximum working pressure of 3 bar.

Remember when calculating heating expansion vessel size to include the capacity of all the pipe work, thermal store and heat emitters.

SFUTS FULLY WIRED AND PLUMBED FOR SOLID FUEL WITH GAS/OIL BOILER ETC

The SFUTS (Solid Fuel Universal Thermal Store) takes the worry out of installation. It offers a fully integrated store with all relevant controls and safety features. It has three pumps fitted - a boiler pump, a heating pump and a re-circulator for the solid fuel device to aid heat up and stratification when the appliance is first lit. The sensor head can be adjusted, we recommend 50°C to 60°C. The sensing probe must be left as supplied, strapped to the pipework.

A heat sink (towel radiator or similar) needs to fitted as shown in the schematic, it should be sized to accommodate 20% of the woodburner output. Two dual thermostats with over-heat protection are fitted (the third is for solar and is left to the installer) and a thermal safety valve is fitted in sealed heating circuits, plumbed in with the pressure relief valve to tun-dish discharge. This valve is thermo-mechanical and will work in the case of an interruption to electrical supply.

A 3amp supply from a fused spur is recommended, and you will need to wire a programmer/ room thermostat to the fitted junction box. Means for disconnection of the supply must be incorporated in the fixed wiring in accordance with the wiring rules. The mains supply wiring must be fixed in a way that prevents it coming into contact with hot parts (those that can experience a temperature rise of $>50^{\circ}\text{C}$), or, that the insulation of the mains supply wiring must be protected, for example, by insulating sleeving having an appropriate temperature rating.

A flue thermostat is supplied loose (but electrically connected) to mount on the flue. This thermostat senses when the appliance is lit/turned on. Some experimentation may be required when setting the flue thermostat temperature. We recommend 70°C to 100°C . It should be mounted using the supplied steel fixing band about 1 metre from the stove. It is wired so that it will turn the solid fuel pump on (in conjunction with the cylinder thermostat) and turn off the boiler when the stove is lit.

Wiring instructions come with the unit. The wiring centre is labelled for 3amp (50HZ) mains input, switched live boiler and programmer connections.

If the supply cord or any wiring on the store is damaged, it must be replaced by the manufacturer, its service agent or similarly qualified persons in order to avoid a hazard.

You will need to connect the boiler flow and return pipes, the solid fuel flow and return and the heating flow and return. Pumps are fitted and pre wired. The solid fuel circuit contains an injector tee, pump and blending valve to prevent cold water being returned to the wood burner.

The unit meets the requirements of G3.

SFUTS SCHEMATIC

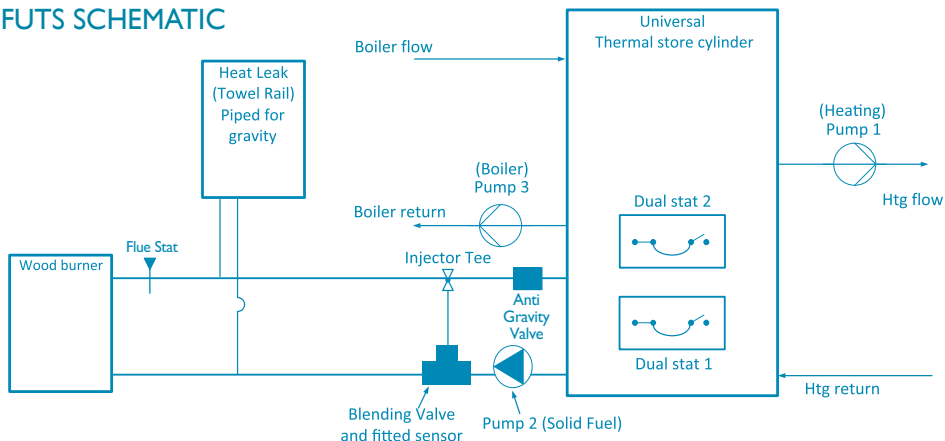

This schematic is for solid fuel pumped circulation.

Note: A heat sink must be fitted

SYSTEMS WITH LOOPED PIPE WORK

If your system looks like this please read note below

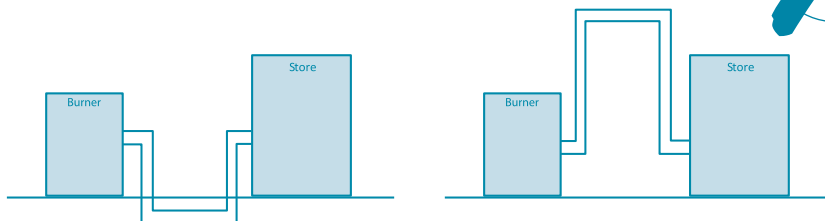

Note: If the pipe runs are as above, the wood burner must have an integrated quench pipe system to protect against overheating or be vented as page 14.

Horizontal

Heat Leak

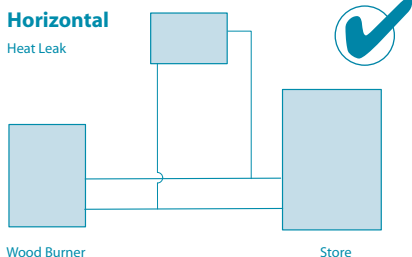

Wood Burner

Store

Store Above

Heat Leak*

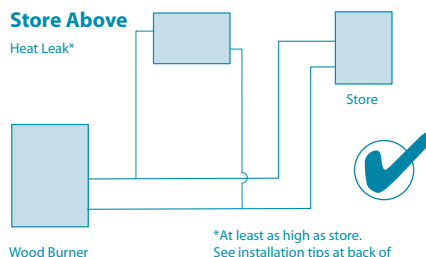

Wood Burner

Store

*At least as high as store.
See installation tips at back of book if heat leak is too hot.

TIMERS FOR BOILER AND SOLID FUEL

Boiler Timer

The boiler should be timed to be on for at least twelve hours to maintain the store temperature. However, it can be a nuisance if it comes on overnight. For your convenience we now fit a pre-wired timer you can set to time the boiler.

Solid Fuel Timer

If the woodburner, for example, is left burning after you go to bed, it will eventually cool but may still activate the pump on the woodburner circuit. To alleviate this we suggest that you set this to off from around midnight and back on in the morning. If the woodburner isn't lit nothing will happen if the timer is on because other controls like the flue thermostat are in the same circuit.

If you light the fire in the morning you will need to be sure that the timer is on. The flue stat is wired so that when the fire is lit the boiler will not come on. If you don't want this feature, link live and 5 in the wiring centre.

Note

You don't have to use these timers - the thermal store works well without them, However they may well aid the efficiency of the operation and prevent nuisance overnight boiler firing and overnight store cooling.

INSTALLATION

Ensure the unit is installed on a flat surface and that all tappings are accessible for future maintenance. Make sure the floor will support the full weight of the unit.

Ensure that there is sufficient safety clearances and air flow around the unit to protect the building fabric, paying special regard to any potential hazard that may cause structural damage to the dwelling.

Please also ensure that the relevant clearances are present for the installation, servicing and/or removal of any valves, thermostats, immersion heaters or further equipment around the thermal storage unit.

The system must be inhibited with a suitable proprietary brand taking account of the store volume. If vented the feed and expansion tank must be at the highest point in the system. A metal feed and expansion tank is preferred.

An expansion vessel of suitable capacity must be installed in sealed systems taking into account the total volume of the heating circuit and thermal store. On page 10 we list the expansion required for the cylinder only.

Install a propriety filling loop system with flexible hose, isolation valve, 3 bar relief valve, expansion vessel and pressure gauge. Fill to 1 bar cold. The filling loop should be installed to prevent back-siphonage.

The relief valve and discharge arrangement is fitted with the thermal safety valve in sealed heating systems. This is a mechanical device (non-electrical) which opens at 97°C and draws cold water through the hot water coil to dissipate heat in the store. It runs via a tun dish which should be connected via a 28mm pipe to a safe low level discharge point, follow G3 advice here. The pressure-relief device is to be operated regularly to remove lime deposits and to verify that it is not blocked.

A 28mm discharge pipe connected to the tun dish is to be installed in a continuously downward direction and in a frost-free environment.

The thermal safety valve gives the third level of protection necessary to meet G3.

An expansion (pressure relief) valve must be fitted into the heating circuit or boiler in addition to the relief valve on the tank.

For solid fuel appliances refer to manufacturer's instructions, especially with regard to heat sinks and so on. Always install a heat sink that will work on gravity between the store and the solid fuel appliance. Contact the stove manufacturers to ensure its suitability for use with a vented or unvented thermal store system.

The SFUTS is pre-wired and pre-plumbed and is simple to install.

Follow the layouts carefully, the pumped solid fuel pipe-set is assembled and supplied packed with SFUTS. It should be attached to the store. If this is not possible it should be less than one metre from the store. Follow the labels on the pipe connections.

Ensure all parts are fitted in accordance with the instructions. On completion of the installation, check all seals for soundness and check that the vessel is functioning correctly. On completion of the installation and commissioning ensure that the operating instructions for the store are left with the customer. Ensure to advise the customer on the correct use of the vessel and setting of controls.

Gravity flow is important in case of power cuts etc. Gravity flow is normally achieved by putting the thermal store on the same level or higher than the woodburner. If this can't be achieved a wood burner with a quench pipe must be installed in case of overheat.

Set the boiler thermostat to 75°C. Set the solid fuel thermostat to 80°C. This will help increase the energy stored in the unit and reduce reliance on fossil fuel. Solar thermal can also operate at 80°C. Boilers must have over-temperature protection and must be able to supply temperatures of at least 75°C. A zone valve and bypass may be necessary for boilers with pump over run if the store temperature is reduced by more than 3°C.

If your boiler has a pump fitted you can remove the boiler pump on the store and disconnect the wiring. It will not affect the operation of the system.

In high risk installations (care homes, nurseries etc.) care should be taken to reduce central heating temperatures with a blending valve. Underfloor heating should be routed through a control manifold. Nuisance gravity circulation should be minimised using either zone valves or non-return valves.

In order to comply with Part L Building Regulations it is necessary to insulate any hot water (primary and secondary) pipework within one metre of the cylinder. Guidance is given in the Table 5 (Page 20) of the 2013 Domestic Heating Compliance guide. Insulation values for the most popular pipe sizes are reproduced below.

Pipe outside diameter	Maximum heat loss in W/m
15	7.89
22	9.12
28	10.07
35	11.08

NOTE: ALL JOINTS MUST BE TESTED AS THEY CAN LOOSEN IN TRANSIT

HOT WATER

If hardness exceeds 200ppm, use a treatment to soften water.

Scale build-up can happen rapidly and reduce flow and efficiency.

Always flush after commissioning but **DO NOT USE** heavily chlorinated solutions unless you are prepared to thoroughly flush the whole heating system after heat up and cool down.

If flow is poor check incoming water supply and make sure all valves etc. are fully open.

If temperature is poor check that the store has reached 75°C and that the tempering valve is set at the appropriate temperature.

Use inhibitor in heating systems. Remember to include the store volume when dosing.

SERVICING

This should be done every year. Fill in the form at the back of this publication - you may need it in case of warranty issues.

Service the shock arrestor by inflating to 3 bar and ensure the store is inhibited with a proprietary brand of inhibitor to the recommended dose.

Check that the tempering valve is controlling hot water temperature at (about) 55°C. To drain the unit isolate all appliances and drain via the fitted drain cock. On sealed systems open the relief valve to allow air into the cylinder to prevent collapse. Please see pages 17 & 18 for full servicing requirements.

WARRANTY

Warranty is for ten years on the tank against failure due to manufacturing fault, and two years on components supplied and fitted to the heating manifold and thermal store.

Conditions apply, the unit must be serviced annually and a record of service must be maintained. It must be in a frost free environment and must be used for public mains potable water only. It must be installed and used correctly in accordance with manufacturer's requirements and current best practice. Corrosion and scale are not covered. Chlorine/chloride levels must be below 200ppm. The store must be inhibited to correct dose.

Scale is not covered. Your statutory rights are not affected by the above.

Upon any malfunction of the unit ensure that the system is switched off and contact the manufacturer, its service agent or a similarly qualified person in order to avoid hazard. Go to www.advanceappliances.co.uk for full terms and conditions and to **register your product** warranty.

COLD SUPPLY

A minimum of 2 bar (200 MPa) pressure through a 22mm pipe is optimum. Below this the performance may be compromised. Test the household supply by turning on mains fed taps to ensure satisfactory flow rates can be achieved.

Above 18 litres per minute is the recommended flow. It is the installer's and householder's responsibility to check these before installation. Excessive flow rates may result in lower hot water temperatures.

Fit a 3 bar (300MPa) control valve (not supplied) if pressures are likely to be in excess of this. This is the maximum recommended coil pressure.

NOTE: Mains pressures usually increase from late evening to early morning.

SIZE & WEIGHT

MODEL	CAPACITY	WEIGHT FULL Kg	EXPANSION VESSEL SIZE (CYLINDER ONLY)*	HGT X DIA mm
SFUTS 210	210 ltrs	280	18 ltrs	1500 x 600
SFUTS 250	250 ltrs	325	24 ltrs	1750 x 600
SFUTS 300	300 ltrs	380	24 ltrs	2025 x 600

* Please add the central heating pipework, radiators/underfloor and appliance volumes to arrive at expansion vessel size.

DISPOSAL

At the end of the life of the product please dispose of in line with any regulations ruling at the time

TECHNICAL SPECIFICATION

MAX COLD WATER PRESSURE		3 BAR		
MAX TANK OPERATING PRESSURE		3 BAR		
MIN OPERATING TEMPERATURE		75°C		
IMMERSION HEATERS		3KW / 230V AC 1 ³ / ₄ " x 14"		
SHOCK ARRESTOR POTABLE		2 LITRE 3 BAR		
HEAT EXCHANGER HOT WATER		35KW		
HEAT EXCHANGER SOLAR		17KW		
HEAT LOSS 210 LITRE	CLASS B	1.67 / 24 HRS	58 WATTS	SOLAR VOLUME 80
HEAT LOSS 250 LITRE	CLASS B	1.77 / 24 HRS	63 WATTS	85
HEAT LOSS 300 LITRE	CLASS B	1.65 / 24 HRS	69 WATTS	90
FOAM GWP / ODP		1 / 0		
SOLAR COIL OUTPUT		20KW (0.75m ²)		
HOT WATER COIL OUTPUT		35KW (1.5m ²)		

SPARE PARTS

2 LITRE EXPANSION VESSEL (SHOCK ARRESTOR)	AA0001
BLENDED VALVE	AA0002B
3KW IMMERSION HEATER 1.75" HIGH TEMP	AA0005
PLUG IN THERMOSTAT IMMERSION	AA0018
NON ADJUSTABLE HI LIMIT THERMOSTAT	AA0030
DUAL CONTROL THERMOSTAT	AA0013
THERMAL SAFETY VALVE	AA0016
WIRING CENTRE	AA0027
FLUE THERMOSTAT	AA0305
28mm INJECTOR TEE	AA0029
A RATED PUMP	AA0031
3 BAR RELIEF VALVE	AA0015

INSTALLATION TIPS

Secondary Circulation

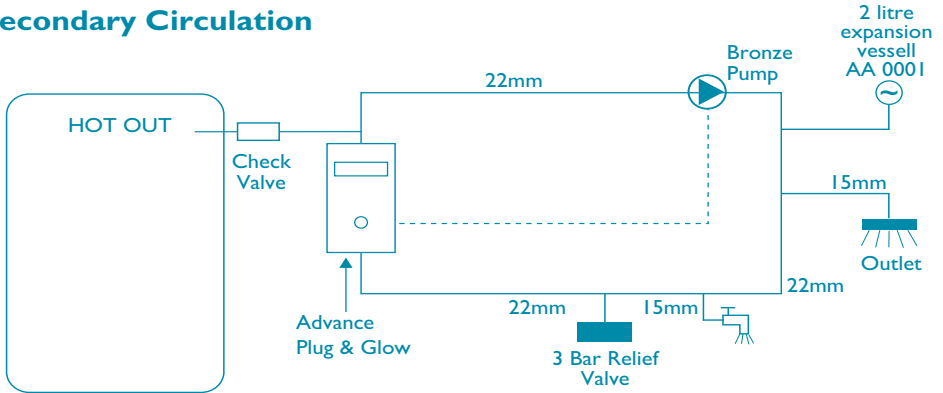

Set the Advance Plug & Glow at 45°C to maintain temperature in the secondary loop without affecting the store temperature, costing just pennies per day.

Nuisance Gravity Circulation

Sometimes circuits may get hot when the heating isn't on. Fit a check valve after the central heating or boiler pump to prevent this. A swing valve is fitted to prevent backflow to the woodburner or heat leak.

Underfloor and Radiator Circuit

If you are installing two separate circuits for underfloor and radiators you can tee off the 28mm primary and reduce to 22mm for each circuit.

If you want to zone these, fit a pump for the underfloor and time it with a programmer/room thermostat.

Use the pump on the store for the radiator circuit and connect the programmer/room thermostat as indicated in the wiring centre.

Fit a non-return valve on the returns from each circuit to prevent nuisance circulation.

Wiring and plumbing for boilers with pump over-run

BY-PASS

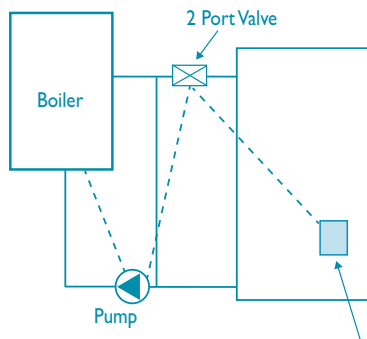

Wired in series so cylinder thermostat on demand will activate the boiler and OPEN the motorised valve (normally closed version)

Connecting two wood burners to SFUTS in series (preferred method)

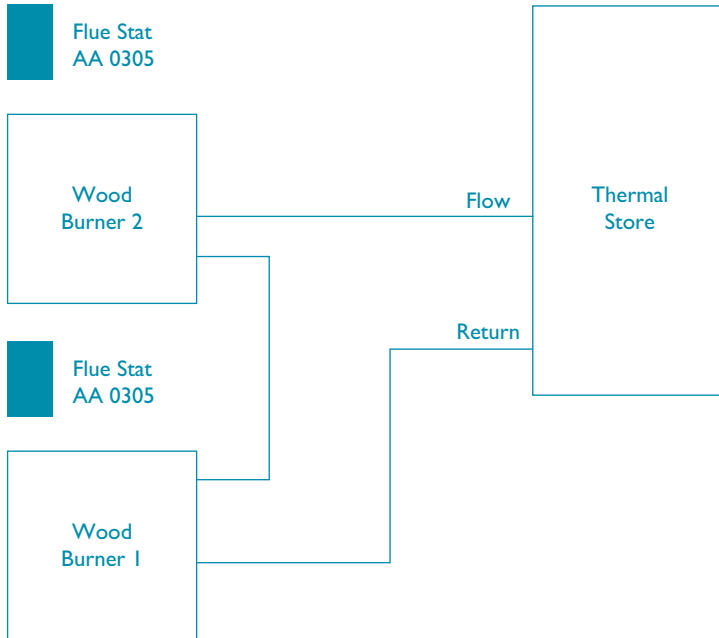

The flue stats are wired in parallel and can be pre-wired on request

Connecting SFUTS to two wood burners in parallel

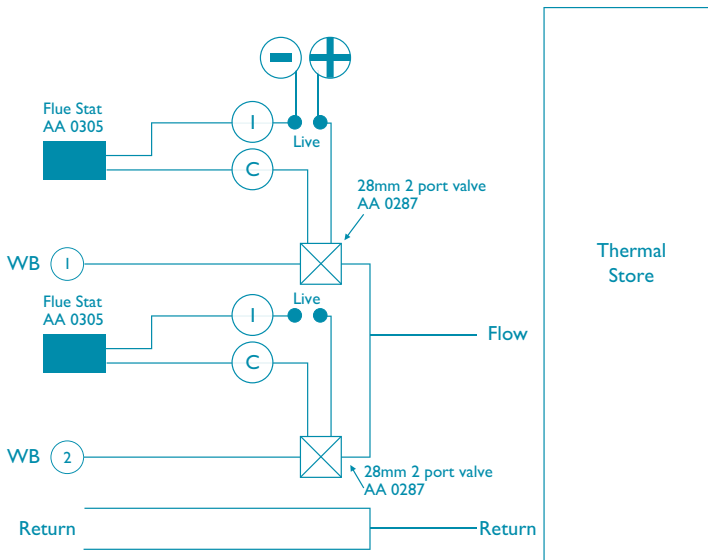

Venting the wood burner circuit

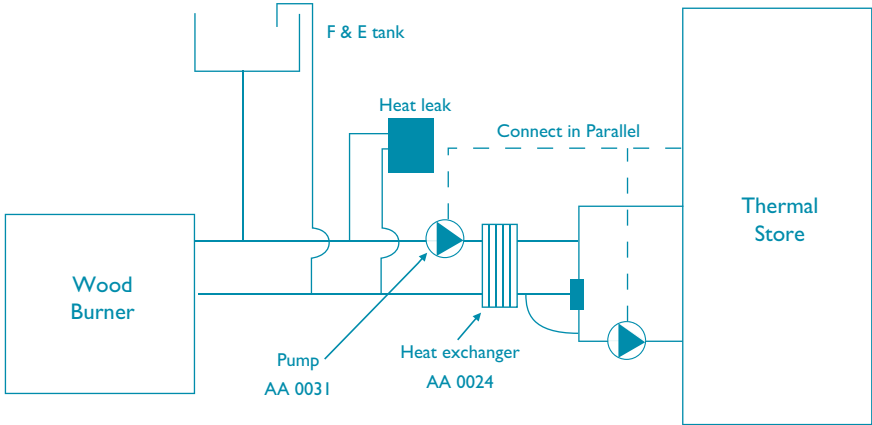

What happens if my heat leak is too hot and robs the store of power?

Fit the following:

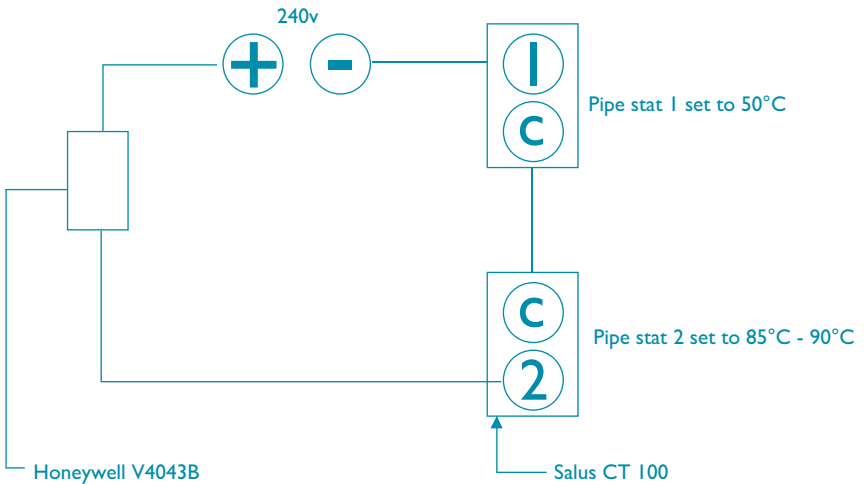
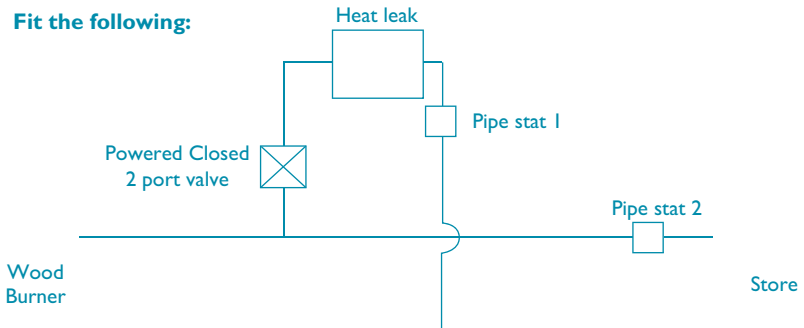

UKCA Declaration of Conformity

In accordance with BS EN ISO/IEC 17050-1:2010

We: Advance Appliances Ltd

Of: Unit 4, Coppice Side Industrial Estate, Brownhills, Walsall, WS8 7EX

declare that:

Equipment: Thermal Store

Model name/number: Universal Thermal Store (UTS) - 210ltr/250ltr/300ltr/400ltr/500ltr

The following UKCA Marking Directives are applicable:

- | | |
|--------------------|--|
| 2006/95/EC | Conforms with the safety objectives of the Low Voltage Directive and its amending Directives |
| 2004/108/EC | Conforms with the essential protection requirements of the Electromagnetic Compatibility Directive and its amending Directives |

and has been designed and manufactured to the following standards:

BS EN 60335-1:2012

Household and similar electrical appliances. Safety. Part 1 - General requirements

BS EN 60335-2-21:03+A2:08+AC:10

Specification for safety of household and similar electrical appliances. Particular requirements for water storage heaters

I hereby declare that the equipment named above has been tested and found to comply with the relevant sections of the above referenced specifications. The unit complies with all essential requirements of the Directives.

Signed by:

Name: Geoff Egginton
Position: Director

On:

The Technical File is held at the above address.

The Year in which the CE mark was first affixed: 2014



COMMISSIONING PROCEDURE INFORMATION

PRIMARY SETTINGS

- IS THE PRIMARY SEALED OR OPEN VENTED SYSTEM Sealed Open
- IF SEALED THEN WHAT IS THE SYSTEM PRESSURE? Hot.....Cold.....BAR
- IF SEALED THEN WHAT IS THE CHARGE PRESSURE OF HEATING EXPANSION VESSELBAR
- WHAT IS THE AVAILABLE BOILER* FLOW TEMPERATURE?°C
- WHAT IS THE BOILER* RETURN TEMPERATURE
- WHEN CYLINDER/STORE IS SATISFIED?°C

ALL MAINS PRESSURE SYSTEMS

- WHAT IS INCOMING COLD WATER PRESSURE?BAR
- HAS A WATER TREATMENT DEVICE BEEN FITTED? YES NO
- IF YES TO ABOVE THEN WHAT TYPE?

THERMAL STORE SYSTEMS ONLY

- IS THE STORE TREATED WITH INHIBITOR? YES NO

(NOTE - FOR INDIRECT THERMAL STORES THE STORE MUST BE TREATED IN ADDITION TO THE PRIMARY SYSTEM) TYPE.....

CONCENTRATION.....

- IS A 3 BAR PRESSURE REDUCING VALVE FITTED? YES NO
- IS THE FITTED SHOCK ARRESTOR FULLY CHARGED AT 3 BAR? YES NO
- IS THE OVERFLOW/WARNING PIPE INSTALLED IN LINE WITH BEST PRACTICE? YES NO
- IF OVERFLOW NOT FITTED IS ISOLATION KIT FITTED AND FUNCTIONAL? YES NO
- IS THE BLENDING VALVE SET AT 55°C? YES NO
- IS THE DHW FLOW CONTROLLED TO THE APPROPRIATE RATE? YES NO
- IF CYLINDER IS IT VENTED CORRECTLY? YES NO
- IS THE CYLINDER STAT SET TO 70°C TO 80°C? YES NO

ALL PRODUCTS

- HAS THE SYSTEM BEEN EXPLAINED TO THE HOUSEHOLDER? YES NO
- HAS THE SYSTEMS LITERATURE BEEN LEFT WITH THE HOUSEHOLDER? YES NO

* Boiler or Heat Pump

ENGINEERS SIGNATURE CUSTOMERS SIGNATURE

ELECTRICAL SAFETY

Incorrectly made electrical connections can result in overheating and risk of fire. When installing the product, please ensure the wiring is adequate to minimise risk of overheating. Please ensure you have:

- Used the correct type and cross sectional area cable to meet manufacturer and Wiring Regulation requirements.
- Stripped the insulation from the individual conductors, taking care to not damage the strands of the conductor wire, which would reduce the cross sectional area of the conductor.
- Ensured the conductors are tightly and securely connected to the terminals, to avoid bearing on the insulation sleeve or only partially clamping the conductors.
- Securely anchored the supply cable using the means provided to avoid exerting any strain to the cable and hence to the terminals.
- Checked to ensure the product is earthed correctly; the Live and Neutral connections are to the correct terminals, and the Residual Current Device (RCD) operates correctly.
- As part of the annual service check the electrical connections to ensure the wires remain in good condition and terminations remain secure. Ensure any spare parts used during maintenance of the product are an authorised spare part and meet the manufacturers' requirement.

The Manufacturers' wiring instructions must always be followed.

ADDITIONAL SERVICE CHECKS

If sealed system check pressure relief valve works by opening manually.
Check pressure of system and pressure of the heating (red) expansion vessel.

INSTALLER & COMMISSIONING ENGINEER DETAILS

Customer Details

Name

Address

.....

Tel No.

Installer Details

Name

Address

.....

Tel No.

DATE

REGISTRATION DETAILS

(where applicable for unvented systems)

REG No.

ID SERIAL No. etc.

Commissioning Engineer Details

Name

Address

.....

Tel No.

DATE

REGISTRATION DETAILS

REG No.

ID SERIAL No. etc.

Servicing Requirements

1. Check pressure reducing valve (if fitted) is 3.0 bar static and adjust if necessary.
2. Check flow rates are correct at 18 litres per minute. Clean filter in pressure reducing valve only if required.
3. Check inhibitor levels in system.
4. Check expansion vessel change is 3.0 bar - inflate as required after decommissioning the cold supply.
5. Check blending valve temperature is 55°C or lower. See manufacturer's installation instructions for any further requirements.

Should further assistance or clarification be required contact Advance Advice on 01543 377723.

Failure to carry out annual service/ maintenance requirements and log proof in service/maintenance records may invalidate warranty.

Appliance Details

Model

Capacity Litres

Serial No.

General Installation

Has a check been done for joint tightness and leaks? Yes No

Has a check been done for electrical safety? Yes No

SERVICE INTERVAL RECORD

Service regularly by an approved engineer and record details below

SERVICE 1

Engineers Name
Company Name
Tel No.
ID Serial No.
Comments
.....
Signature

SERVICE 2

Engineers Name
Company Name
Tel No.
ID Serial No.
Comments
.....
Signature

SERVICE 3

Engineers Name
Company Name
Tel No.
ID Serial No.
Comments
.....
Signature

SERVICE 4

Engineers Name
Company Name
Tel No.
ID Serial No.
Comments
.....
Signature

SERVICE 5

Engineers Name
Company Name
Tel No.
ID Serial No.
Comments
.....
Signature

SERVICE 6

Engineers Name
Company Name
Tel No.
ID Serial No.
Comments
.....
Signature

SERVICE 7

Engineers Name
Company Name
Tel No.
ID Serial No.
Comments
.....
Signature

SERVICE 8

Engineers Name
Company Name
Tel No.
ID Serial No.
Comments
.....
Signature

HOT WATER ASSOCIATION CHARTER MEMBER

Hot Water Association (HWA) Members undertake to offer their customers the following:

- To supply fit for purpose products clearly and honestly described
- To supply products that meet or exceed appropriate standards and building and water regulations
- To provide pre and post sales technical support
- To provide clear and concise warranty details to customers



www.hwacharter.org



UNIT 4 COPPICE SIDE IND EST BROWNHILLS WALSALL WS8 7EX TEL 01543 377723
For Terms and Conditions go to www.advanceappliances.co.uk