



## INSTALLATION AND USER GUIDE

# ADVANCE STANDARD THERMAL STORE



[www.hwacharter.org](http://www.hwacharter.org)

## ADVANCE APPLIANCES LTD

**PLEASE RETAIN AND ENSURE SERVICE RECORDS  
ARE KEPT UP TO DATE.**

## TSD - DIRECT (SINGLE COIL) WITH INTEGRATED F & E TANK

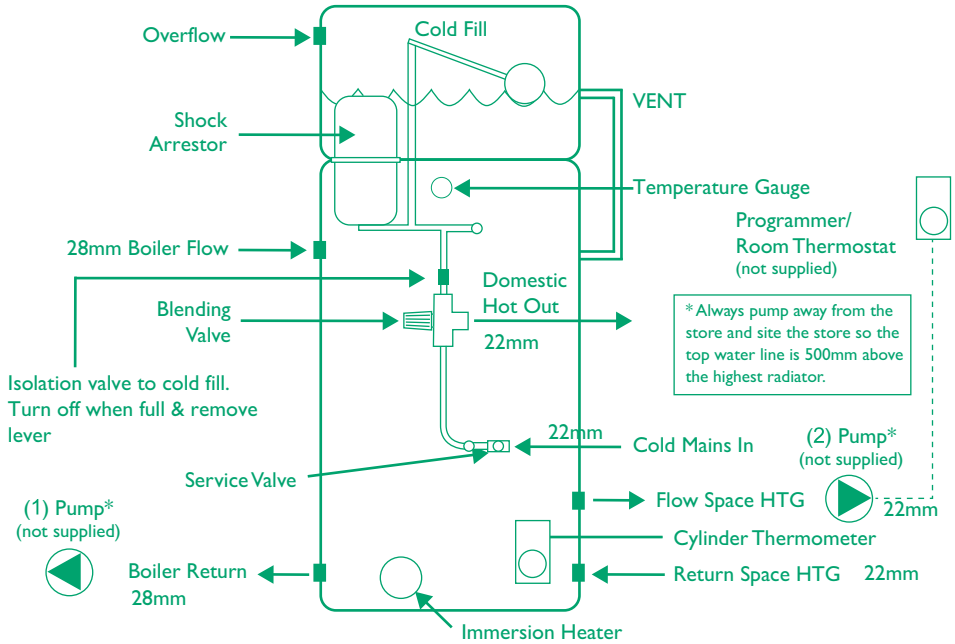

## TSi - INDIRECT (TWIN COIL) WITH INTEGRATED F & E TANK

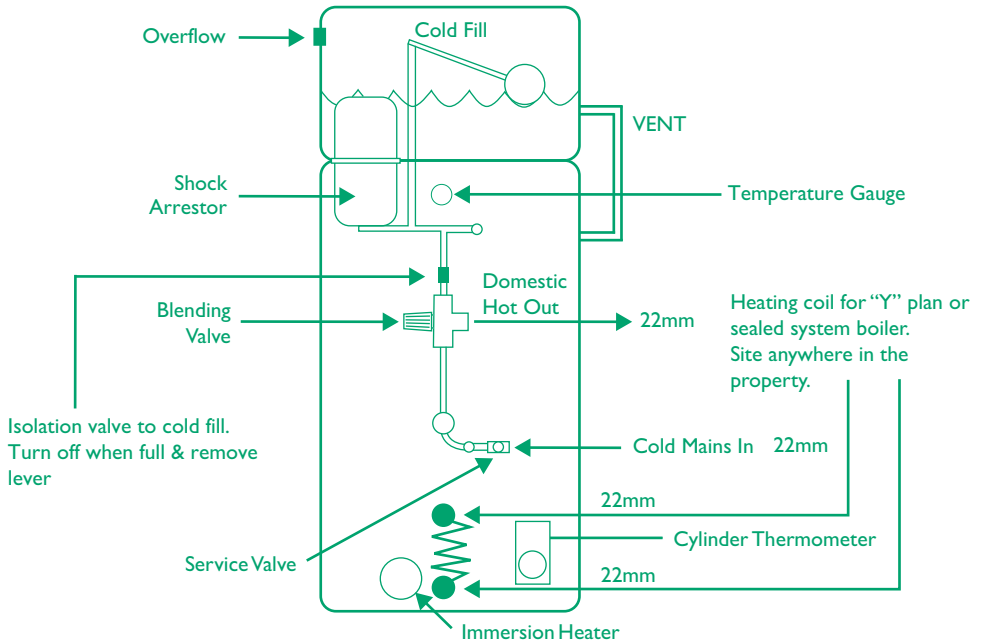

## TSDC - DIRECT (SINGLE COIL) CYLINDER ONLY

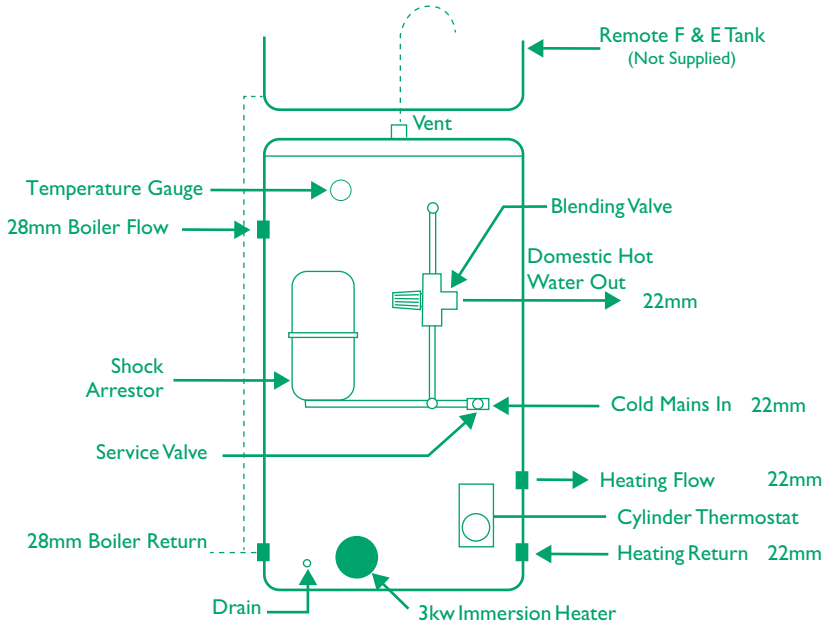

## TsIC - INDIRECT (TWIN COIL) CYLINDER ONLY

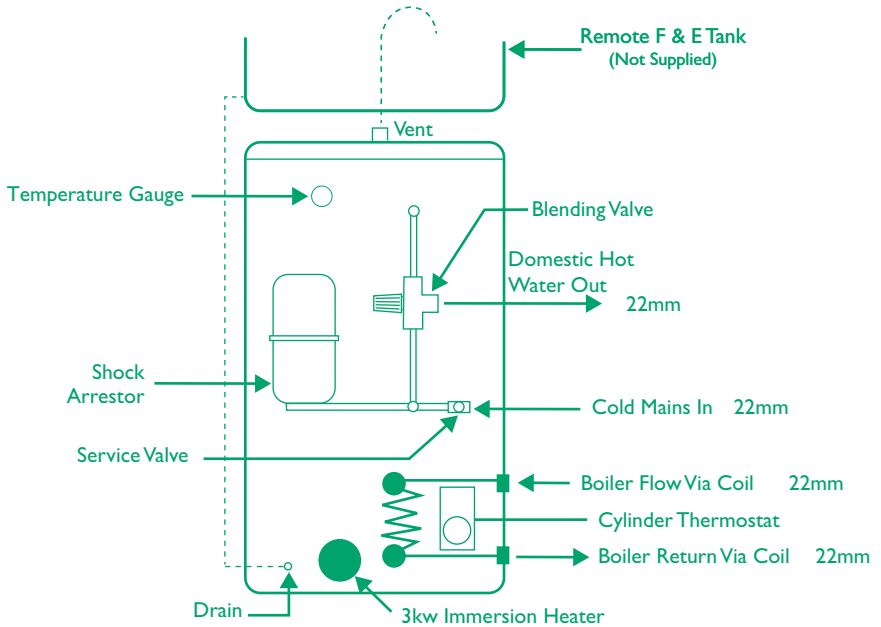

## INTRODUCTION

Advance thermal stores meet the Hot Water Association Thermal Store Specification and Part G and Part L of the Building Regulations.

Advance Thermal Store units for gas/oil/LPG boilers or biomass etc store a bank of hot water at 75 degrees centigrade for central heating, and they utilise an internal, efficient heat exchanger to supply domestic hot water for showering and fast bath filling. The blending valve is set at 50°C and can be adjusted.

Do not set it at maximum as this will deplete store energy too quickly.

## COLD SUPPLY

A minimum of 2 bar pressure through a 22mm pipe is optimum. Below this the performance may be compromised. Test the household supply by turning on mains fed taps to ensure satisfactory flow rates can be achieved.

Above 18 litres per minute is the recommended flow. It is the installer's and householder's responsibility to check these before installation.

Fit a 3 bar control valve (not supplied) if pressures are likely to be in excess of this.

NOTE: Mains pressures usually increase from late evening to early morning.

## INSTALLING & PROBLEM SOLVING

Fully pumped systems are suitable, solid fuel systems can be gravity fed.

Ensure the unit is installed on a flat, level surface and that it is accessible for future maintenance and that the floor will support the weight of the unit. The weights are published in the technical data section at the back of this publication.

Please make sure all parts are accessible for future maintenance, ESPECIALLY immersion heaters. Units must be in a frost free environment.

There are two types of thermal store available, DIRECT units (single coil) and INDIRECT (twin coil).

Two patterns are available. The TSD and TSi are fitted with integrated feed and expansion tanks. Isolate the float valve feed when full by turning off fitted valve. Remove plastic lever to prevent customer error. The TSDC and TSiC are cylinder types without the F&E tank fitted.

The TSD MUST be fitted with the feed and expansion section ABOVE the radiator circuit. The top level of the water in the feed and expansion tank must be at least 400mm above the highest radiator or pipe in the heating system.

Set the thermostat to 75 degrees. Most boilers will achieve this temperature and some may exceed it. Searching between cylinder and boiler thermostats must be avoided. Advice on wiring is given below.

If hardness exceeds 200ppm, use a treatment to soften water. Scale build-up can happen rapidly and reduce flow and efficiency.

Always flush after commissioning but **DO NOT USE** heavily chlorinated solutions unless you are prepared to thoroughly flush the whole heating system after heat up and cool down.

Use inhibitor in heating systems. For **DIRECT** models allow for extra capacity of the store. For **INDIRECT** models inhibit the heating system and the store separately.

If flow is poor, check incoming water supply and make sure all valves etc. are fully open.

If temperature is poor, check thermostat is set at 75 degrees and that the blending valve is set at the appropriate temperature. Check that the temperature gauge is 75°C.

Check all controls. Always set boilers to maximum. Always use an appropriate boiler size (see technical data). Modulating boilers may compromise performance by extending recovery times. Boilers or any heat resources must be capable of reaching 75°C output.

The overflow must be metal or solvent weld, at least 22mm in diameter and set in continuous fall to a safe point outside the building. We suggest you isolate the ballcock by turning off the isolation valve.

Continuous dripping may be caused by a high level of water in the cold section, in which case adjust the position of the ball float valve. If it is a faulty valve, replace and re-commission. The lid can easily be removed. If the problem persists, shut off cold mains to check integrity of heat exchanger. If this is breached, replace the unit.

**NOTE: ALL JOINTS CAN LOOSEN IN TRANSIT AND MUST BE CHECKED ON COMMISSIONING**

## **SERVICING**

This should be done every year. Fill in the form at the back of this publication - you may need it in case of warranty issues. Keep proof of servicing (receipts etc).

Service the expansion vessel by inflating to 3 bar, check condition of ball and float valve and ensure store is inhibited with a proprietary brand of inhibitor.

## **WIRING**

For indirect (twin coil) units a Y,S or W plan can be used.

For direct units, two pumps must be used. Pump No. 1 and the boiler should be linked to the cylinder stat. Pump No. 2 should be connected to the room thermostat and programmer to call for space heating.

Boilers with pump over-run may deplete store temperatures. Consult the boiler manufacturer for advice on fitting a by-pass to overcome this (see page 10).

# INSTALLING THE INDIRECT (TSI/TSIC) TWIN COIL THERMAL STORE

## Layout Plan

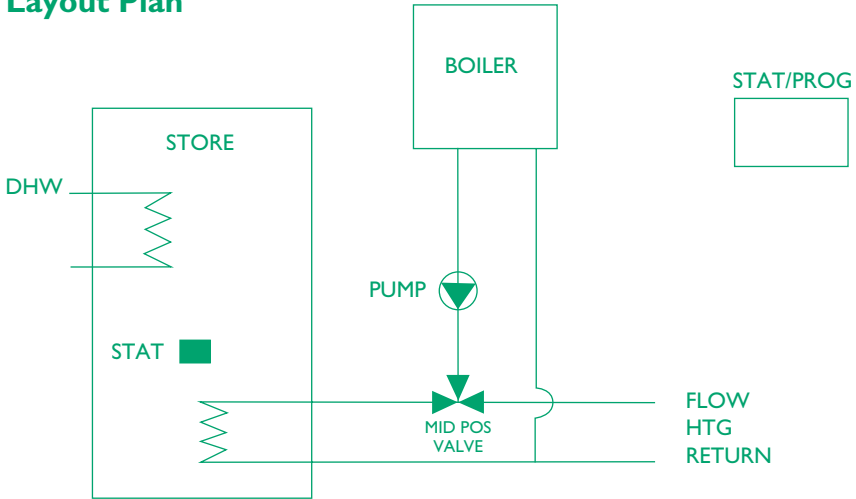

## Wiring Y Plan

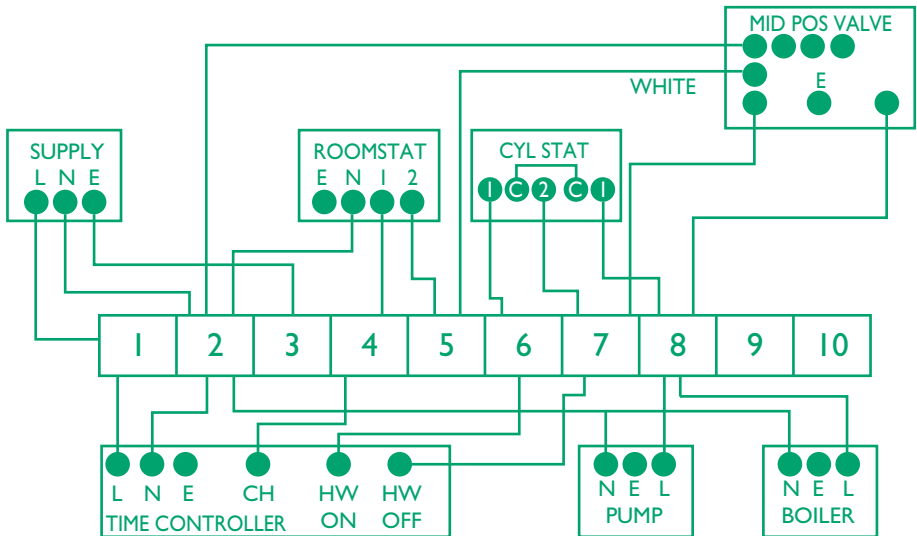

# INSTALLING THE INDIRECT (TSI/TSIC) TWIN COIL THERMAL STORE

## General Layout S Plan

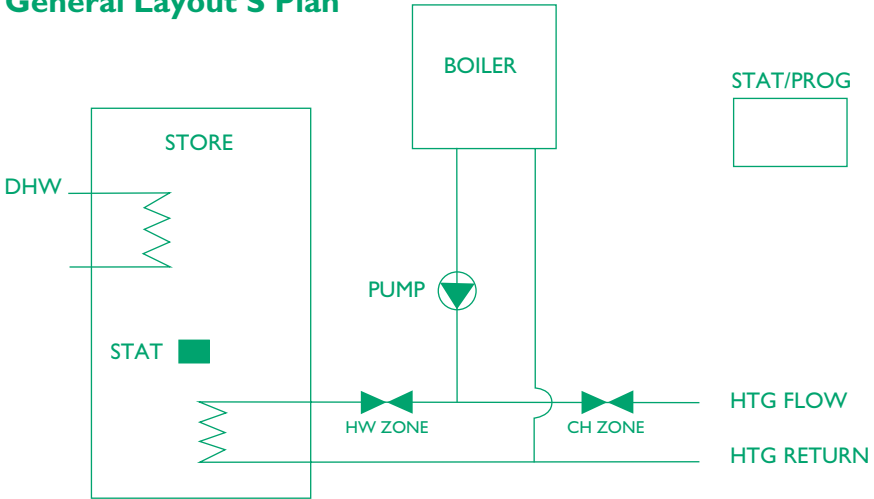

## Wiring S Plan

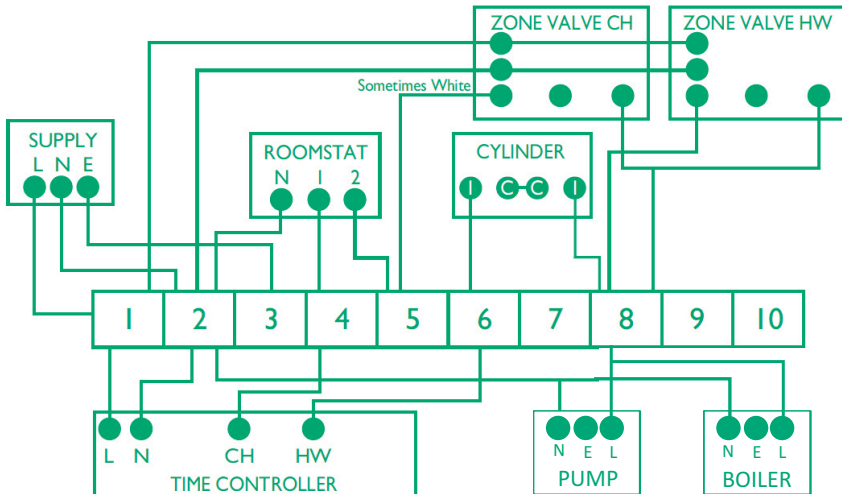

# INSTALLING THE DIRECT (TSD/TSDC) SINGLE COIL THERMAL STORE

## General Layout

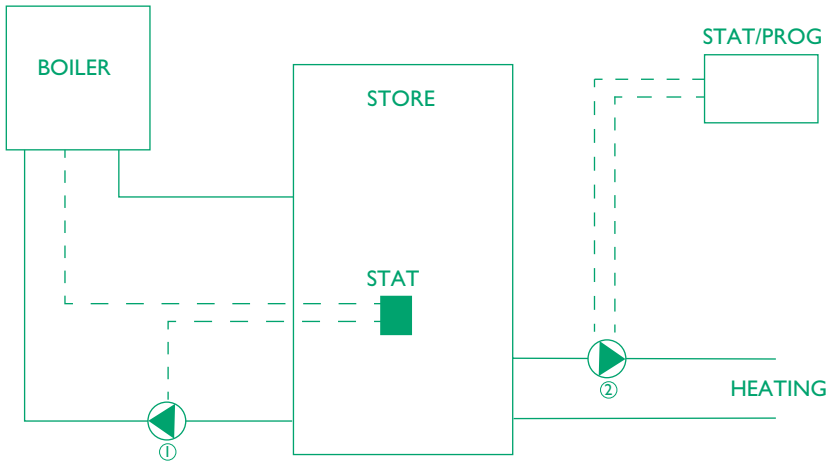

Pump away from the store

The cylinder thermostat switches the boiler and pump ①

The room stat/programmer switches the heating pump ②

## Wiring

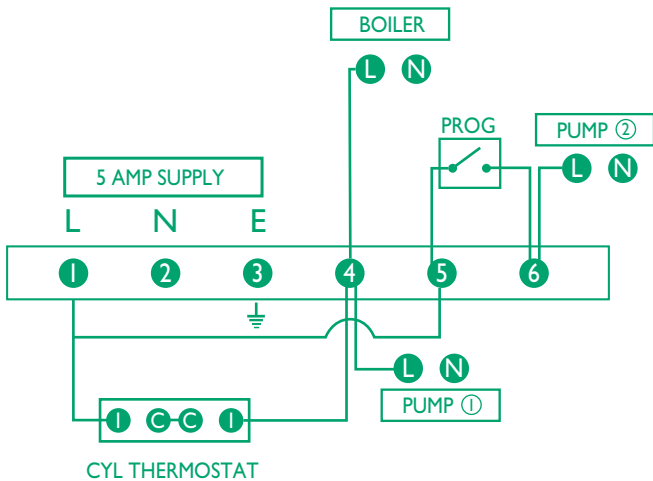



## USING THE UNIT

Programme the boiler to be on for at least twelve hours per day, especially during periods when there is a hot water demand as this will ensure proper operation (see wiring page 6).

DO NOT be tempted to reduce the thermostat temperature below 75°C. Thermal Stores operate at higher temperatures than storage systems and are economical to run at these temperatures

## WARRANTY

Warranty is for ten years on the tank against failure due to manufacturing fault, and two years on components supplied and fitted to the hot water manifold and thermal store.

Conditions apply, the unit must be serviced annually and a record of service must be maintained. It must be in a frost free environment and must be used for public mains potable water only. It must be installed and used correctly in accordance with manufacturer's requirements and current best practice. Corrosion and scale are not covered. Chlorine/chloride levels must be below 200ppm. The store must be inhibited to correct dose.

Scale is not covered. Your statutory rights are not affected by the above.

For full terms and conditions and **to register your product** please go to [www.advanceappliances.co.uk](http://www.advanceappliances.co.uk)

## TECHNICAL DATA

CAPACITY	WEIGHT FULL Kg	RECOMMENDED BOILER SIZE	HGT X DIA mm	
			WITH COLD SECTION	WITHOUT COLD SECTION
140 ltrs	190	40,000 BTU/12KW	1285 x 600	1086 x 600
170 ltrs	225	60,000 BTU/18KW	1475 x 600	1243 x 600
210 ltrs	270	80,000 BTU/24KW	1735 x 600	1485 x 600
250 ltrs	315	100,000 BTU/30KW	1975 x 600	1753 x 600

CAPACITY	PRIMARY COIL SURFACE AREA M <sup>2</sup> IF FITTED	HOT WATER COIL SURFACE AREA M <sup>2</sup>	PRIMARY COIL KW OUTPUT IF FITTED	HOT WATER TEMP	HOT WATER COIL KW OUTPUT	HEAT LOSS WATTS	HOT WATER DELIVER 43°C	CLASS
140	0.8	1.4	21	50	35	43	140	B
170	0.8	1.4	21	50	35	50	170	B
210	0.8	1.4	21	50	35	58	210	B
250	0.8	1.4	21	50	35	63	250	B

# DISPOSAL

At the end of the life of the product please dispose of in line with any regulations ruling at the time

# SPARE PARTS

EXPANSION VESSEL	AA0001	THERMOSTAT	AA0013
BLENDED VALVE	AA0002B	IMMERSION HEATER	AA0005

# INSTALLATION TIPS

## Secondary Circulation

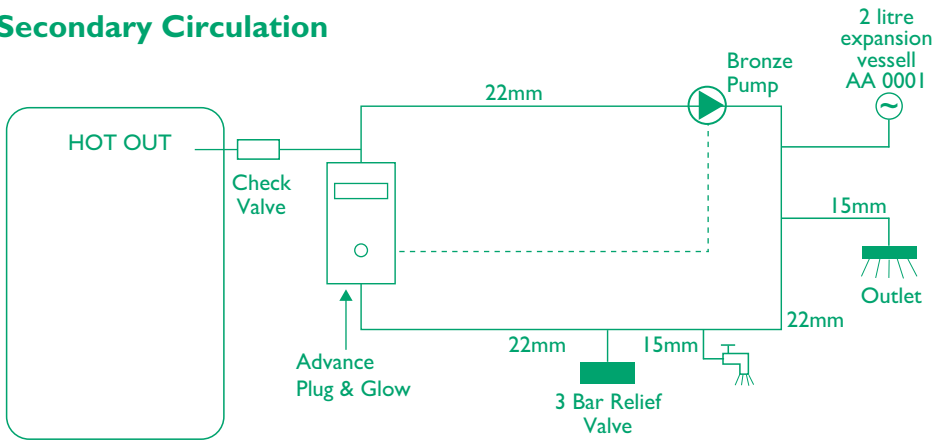

Set the Advance Plug & Glow at 45°C to maintain temperature in the secondary loop without affecting the store temperature, costing just pennies per day.

## Nuisance Gravity Circulation

Sometimes circuits may get hot when the heating isn't on. Fit a check valve after the central heating or boiler pump to prevent this.

## BY-PASS FOR BOILERS WITH TIMED OVER-RUN

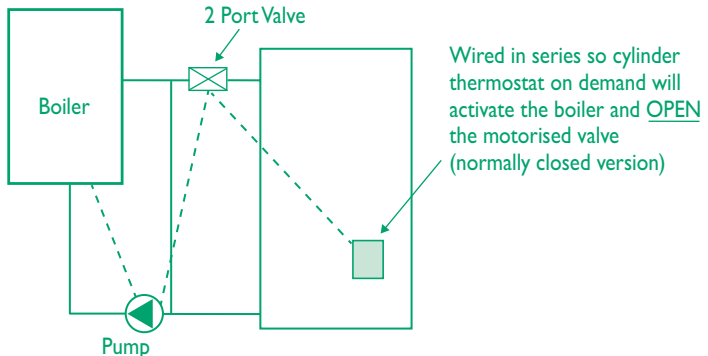

## COVERTING THE DIRECT MODEL TO SEALED SYSTEM

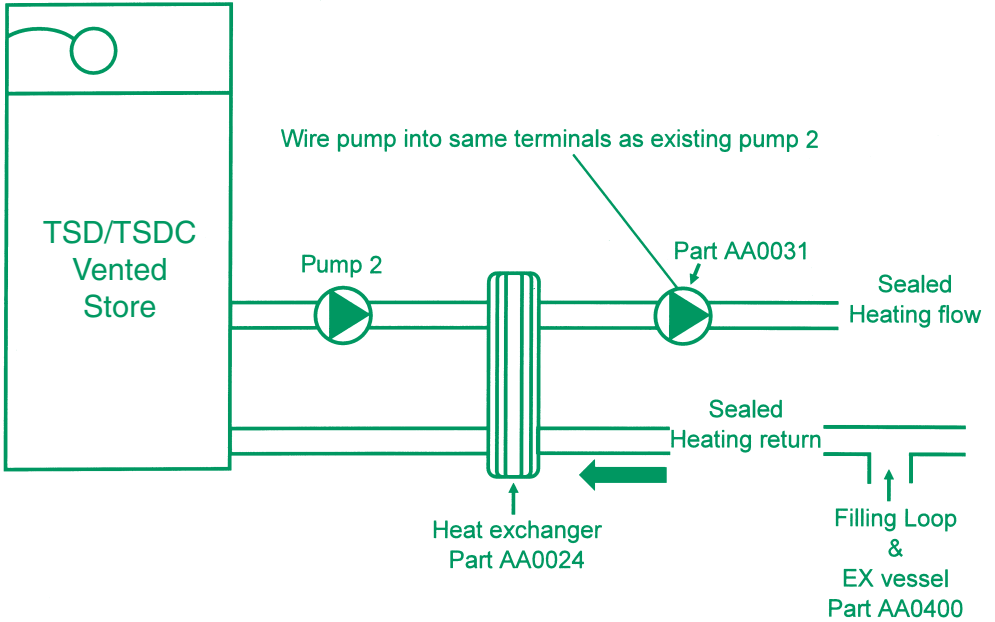

## CONNECTING A SEALED BOILER TO A VENTED THERMAL STORE

WIRE PUMPS INTO THE SAME TERMINALS

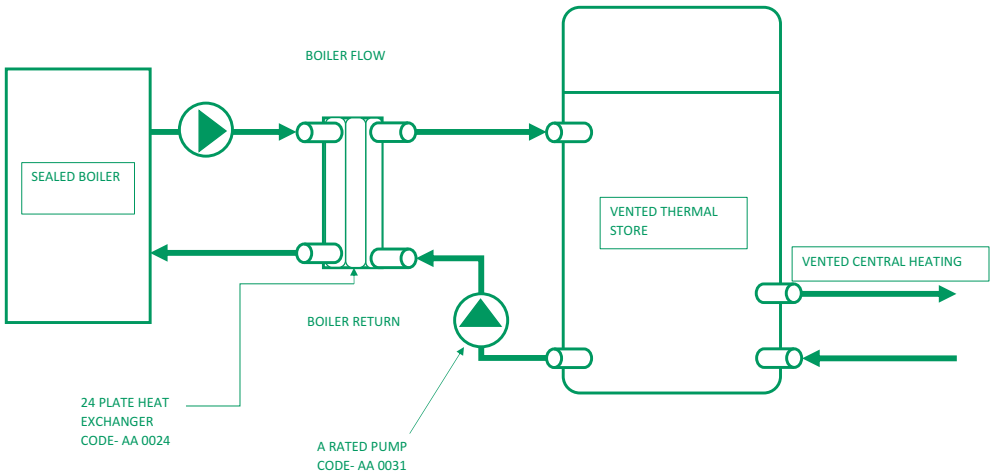

# INSTALLING A TIMER FOR THE BOILER (DIRECT ONLY)

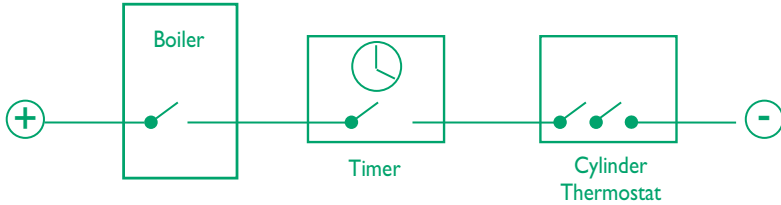

## COMMISSIONING PROCEDURE INFORMATION

### PRIMARY SETTINGS

- IS THE PRIMARY SEALED OR OPEN VENTED SYSTEM Sealed  Open   
 IF SEALED THEN WHAT IS THE SYSTEM PRESSURE? Hot.....Cold.....BAR  
 IF SEALED THEN WHAT IS THE CHARGE PRESSURE OF HEATING EXPANSION VESSEL .....BAR  
 WHAT IS THE AVAILABLE BOILER\* FLOW TEMPERATURE? .....°C  
 WHAT IS THE BOILER\* RETURN TEMPERATURE  
 WHEN CYLINDER/STORE IS SATISFIED? .....°C

### ALL MAINS PRESSURE SYSTEMS

- WHAT IS INCOMING COLD WATER PRESSURE? .....BAR  
 HAS A WATER TREATMENT DEVICE BEEN FITTED? YES  NO   
 IF YES TO ABOVE THEN WHAT TYPE? .....

### THERMAL STORE SYSTEMS ONLY

- IS THE STORE TREATED WITH INHIBITOR? YES  NO   
 (NOTE - FOR INDIRECT THERMAL STORES THE STORE MUST BE TREATED IN  
 ADDITION TO THE PRIMARY SYSTEM) TYPE.....  
 CONCENTRATION.....

- IS A 3 BAR PRESSURE REDUCING VALVE FITTED? YES  NO   
 IS THE FITTED SHOCK ARRESTOR FULLY CHARGED AT 3 BAR? YES  NO   
 IS THE OVERFLOW/WARNING PIPE INSTALLED IN LINE WITH  
 BEST PRACTICE? YES  NO   
 IF OVERFLOW NOT FITTED IS ISOLATION KIT FITTED AND FUNCTIONAL? YES  NO   
 IS THE BLENDING VALVE SET AT 55°C? YES  NO   
 IS THE DHW FLOW CONTROLLED TO THE APPROPRIATE RATE? YES  NO   
 IF CYLINDER IS IT VENTED CORRECTLY? YES  NO   
 IS THE CYLINDER STAT SET TO 70°C TO 80°C? YES  NO

### ALL PRODUCTS

- HAS THE SYSTEM BEEN EXPLAINED TO THE HOUSEHOLDER? YES  NO   
 HAS THE SYSTEMS LITERATURE BEEN LEFT WITH THE HOUSEHOLDER? YES  NO

\* Boiler or Heat Pump

ENGINEERS SIGNATURE ..... CUSTOMERS SIGNATURE .....

## ELECTRICAL SAFETY

Incorrectly made electrical connections can result in overheating and risk of fire. When installing the product, please ensure the wiring is adequate to minimise risk of overheating. Please ensure you have:

- Used the correct type and cross sectional area cable to meet manufacturer and Wiring Regulation requirements.
- Stripped the insulation from the individual conductors, taking care to not damage the strands of the conductor wire, which would reduce the cross sectional area of the conductor.
- Ensured the conductors are tightly and securely connected to the controls or immersion heater.
- Ensured the bared conductors are correctly inserted into the terminals, to avoid bearing on the insulation sleeve or only partially clamping the conductors.
- Securely anchored the supply cable using the means provided to avoid exerting any external strain to the cable and hence to the terminals
- Checked to ensure the product is earthed correctly; the Live and Neutral connections are to the correct terminals, and the Residual Current Device (RCD) operates correctly.
- As part of the annual service checked the electrical connections to ensure the wires remain in good condition and terminations remain secure. Ensure any spare parts used during maintenance of the product are an authorised spare part and meet the manufacturers' requirement.

The Manufacturers' wiring instructions must always be followed.

## PIPE WORK

In order to comply with Part L Building Regulations it is necessary to insulate any hot water (primary and secondary) pipework within one metre of the cylinder. Guidance is given in the Table 5 (Page 20) of the 2013 Domestic Heating Compliance guide. Insulation values for the most popular pipe sizes are reproduced below.

Pipe outside diameter	Maximum heat loss in W/m
15	7.89
22	9.12
28	10.07
35	11.08

## INSTALLER & COMMISSIONING ENGINEER DETAILS

### Customer Details

Name .....

Address .....

Tel No. ....

### Installer Details

Name .....

Address .....

Tel No. ....

DATE .....

REGISTRATION DETAILS  
(where applicable for unvented systems)

REG No. ....

ID SERIAL No. etc. ....

### Commissioning Engineer Details

Name .....

Address .....

Tel No. ....

DATE .....

REGISTRATION DETAILS

REG No. ....

ID SERIAL No. etc. ....

### Servicing Requirements

1. Check pressure reducing valve (if fitted) is 3.0 bar static and adjust if necessary.
2. Check flow rates are correct at 18 litres per minute. Clean filter in pressure reducing valve only if required.
3. Check inhibitor levels in system.
4. Check expansion vessel charge is 3.0 bar - inflate as required after decommissioning the cold supply.
5. Check safe blending valve temperature is 55°C or lower

Should further assistance or clarification be required contact Advance Advice on 01543 377723.

Failure to carry out annual service/maintenance requirements and log proof in service/maintenance records may invalidate warranty.

### Appliance Details

Model .....

Capacity ..... Litres

Serial No. ....

### General Installation

Has a check been done for joint tightness and leaks? Yes  No

Has a check been done for electrical safety? Yes  No

# SERVICE INTERVAL RECORD

Service regularly by an approved engineer and record details below

## SERVICE 1

Engineers Name .....  
Company Name .....  
Tel No. ....  
ID Serial No. ....  
Comments .....  
.....  
Signature .....

## SERVICE 2

Engineers Name .....  
Company Name .....  
Tel No. ....  
ID Serial No. ....  
Comments .....  
.....  
Signature .....

## SERVICE 3

Engineers Name .....  
Company Name .....  
Tel No. ....  
ID Serial No. ....  
Comments .....  
.....  
Signature .....

## SERVICE 4

Engineers Name .....  
Company Name .....  
Tel No. ....  
ID Serial No. ....  
Comments .....  
.....  
Signature .....

## SERVICE 5

Engineers Name .....  
Company Name .....  
Tel No. ....  
ID Serial No. ....  
Comments .....  
.....  
Signature .....

## SERVICE 6

Engineers Name .....  
Company Name .....  
Tel No. ....  
ID Serial No. ....  
Comments .....  
.....  
Signature .....

## SERVICE 7

Engineers Name .....  
Company Name .....  
Tel No. ....  
ID Serial No. ....  
Comments .....  
.....  
Signature .....

## SERVICE 8

Engineers Name .....  
Company Name .....  
Tel No. ....  
ID Serial No. ....  
Comments .....  
.....  
Signature .....

## HOT WATER ASSOCIATION CHARTER MEMBER

**Hot Water Association (HWA) Members undertake to offer their customers the following:**

- To supply fit for purpose products clearly and honestly described
- To supply products that meet or exceed appropriate standards and building and water regulations
- To provide pre and post sales technical support
- To provide clear and concise warranty details to customers



[www.hwacharter.org](http://www.hwacharter.org)



UNIT 4 COPPICE SIDE IND EST BROWNHILLS WALSALL WS8 7EX TEL 01543 377723  
For Terms and Conditions go to [www.advanceappliances.co.uk](http://www.advanceappliances.co.uk)